

ER5J ULTRAFAST PLASTIC RECTIFIER

Features:

- Glass Passivated Die Construction
- Ideally Suited for Automatic Assembly
- Low Forward Voltage Drop, High Efficiency
- Surge Overload Rating to 100 A Peak
- Low Power Loss
- Super Fast Recovery Time
- Plastic Case Material has UL Flammability Classification Rating 94V-O
- Green Products in Compliance with the ROHS Directive
- This is a Pb – Free Device
- All SMC parts are traceable to the wafer lot
- Additional testing can be offered upon request

Mechanical Data:

- Case: Low Profile Molded Plastic
- Terminals: Solder Plated, Solderable per MIL-STD-750, Method 2026
- Polarity :Cathode Band or Cathode Notch
- Weight: 0.21 grams (approx.)
- Marking: Type Number

Mechanical Dimensions: In mm

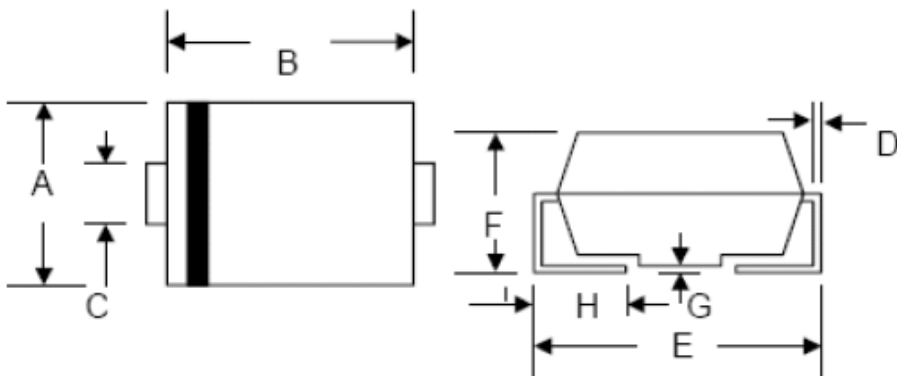

Dim.	SMC/DO-214AB			
	Min.	Max.	Min.	Max.
A	5.59	6.22	0.220	0.245
B	6.60	7.11	0.260	0.280
C	2.75	3.25	0.108	0.128
D	0.152	0.305	0.006	0.012
E	7.75	8.25	0.305	0.325
F	2.00	2.95	0.079	0.116
G	0.051	0.203	0.002	0.008
H	0.76	1.60	0.030	0.063
	In mm		In inch	

OPTION 1

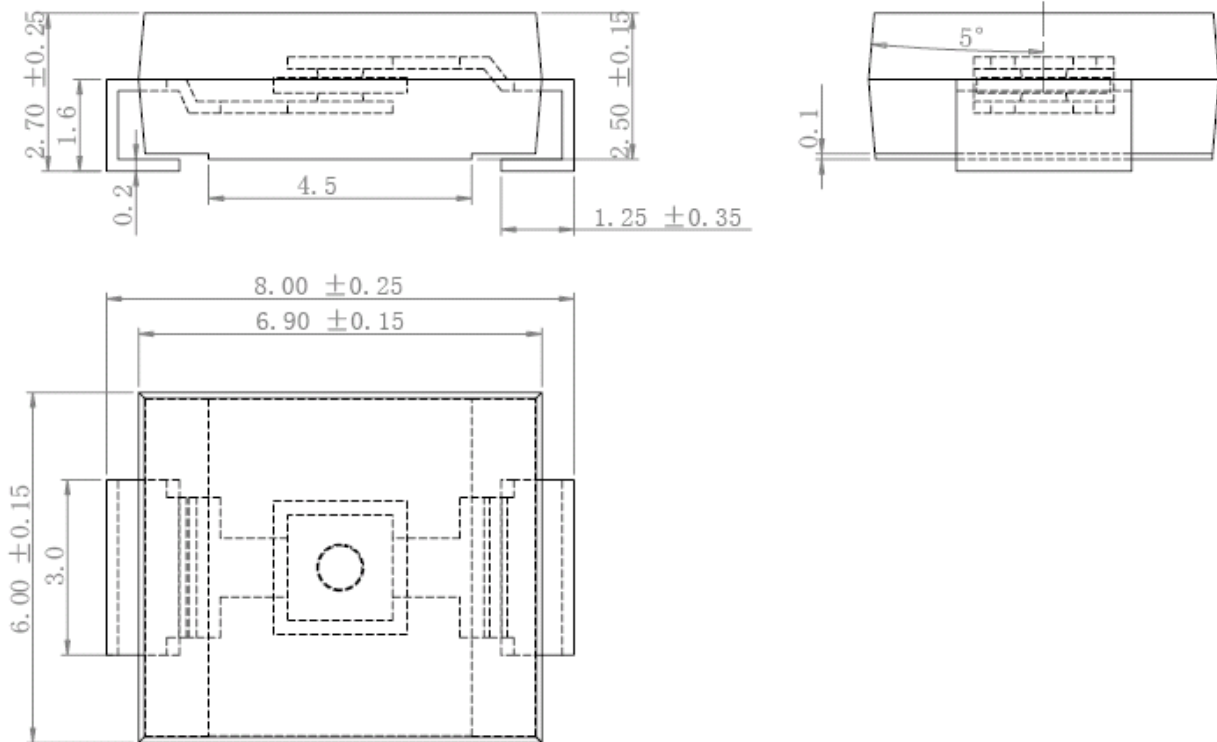

OPTION 2(JK)

SMC

Marking Diagram:

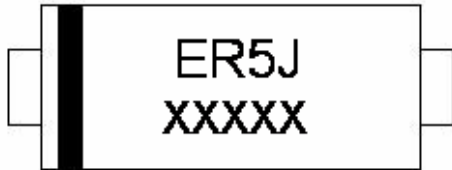

Where XXXXX is YYWWL

ER = Device Type
5 = Forward Current (5A)
J = Reverse Voltage (600V)
YY = Year
WW = Week
L = Lot Number

Cautions: Molding resin
Epoxy resin UL:94V-0

Ordering Information:

Device	Package	Shipping
ER5J	SMC (Pb-Free)	3000pcs / reel

For information on tape and reel specifications, including part orientation and tape sizes, please refer to our Tape and Reel Packaging Specification.

Maximum Ratings and Electrical Characteristics @ $T_A=25^\circ\text{C}$ unless otherwise specified

Characteristic	Symbol	ER5J	Unit
Peak Repetitive Reverse Voltage Working Peak Reverse Voltage DC Blocking Voltage	V_{RRM} V_{RWM} V_R	600	V
Average Rectified Output Current @ $T_L = 75^\circ\text{C}$	I_o	5.0	A
Non-Repetitive Peak Forward Surge Current 8.3ms Single half sine-wave superimposed on rated load (JEDEC Method)	I_{FSM}	150	A
Forward Voltage @ $I_F = 5.0\text{A}$, $T_J=25^\circ\text{C}$	V_F	1.7	V
Peak Reverse Current @ $T_A = 25^\circ\text{C}$ At Rated DC Blocking Voltage @ $T_A = 100^\circ\text{C}$	I_{RM}	5.0 100	μA
Typical Thermal Resistance Junction to Lead (Note 1)	$R_{\theta JL}$	47	K/W
Typical Junction Capacitance (Note 2)	C_J	58	pF
Maximum Reverse Recovery Time (Note 3)	T_{rr}	35	ns
Operating and Storage Temperature Range	T_J, T_{STG}	-55 to +150	$^\circ\text{C}$
Case Style	SMC		

- Note: 1. Mounted on P.C. Board with 8.0mm² lead area
 2. Measured at 1.0 MHz and applied reverse voltage of 4.0 VDC.
 3. Measured with $I_F=0.5\text{A}$; $I_R=1.0\text{A}$; $I_{RR}=0.25\text{A}$

AVERAGE FORWARD RECTIFIED CURRENT,
AMPERES

FIG. 1- FORWARD CURRENT DERATING CURVE

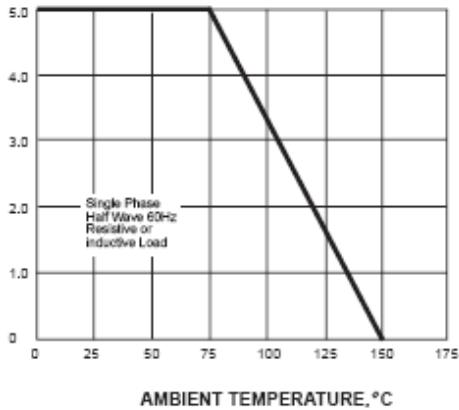

PEAK FORWARD SURGE CURRENT,
AMPERES

FIG. 2-MAXIMUM NON-REPETITIVE PEAK FORWARD SURGE CURRENT

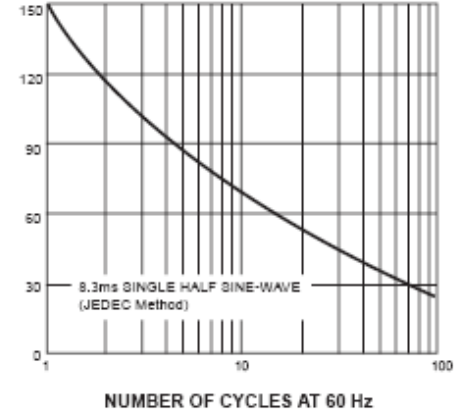
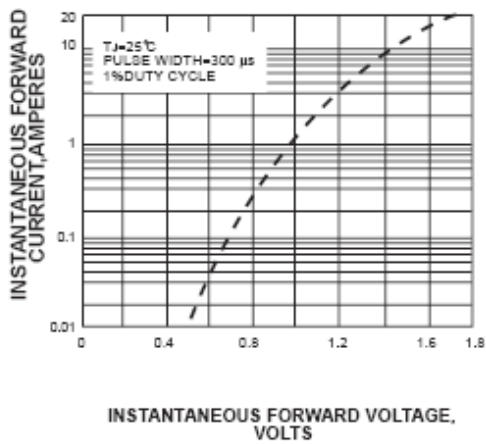

FIG. 3-TYPICAL INSTANTANEOUS FORWARD CHARACTERISTICS



INSTANTANEOUS REVERSE CURRENT,
MICROAMPERES

FIG. 4-TYPICAL REVERSE CHARACTERISTICS

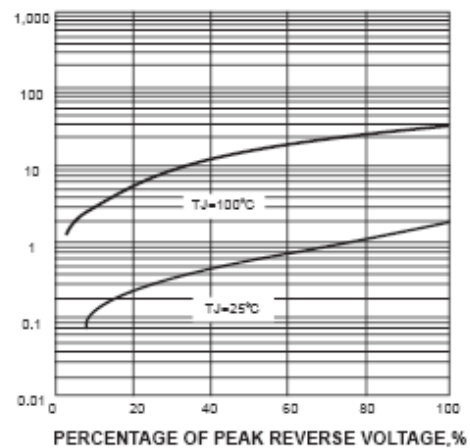
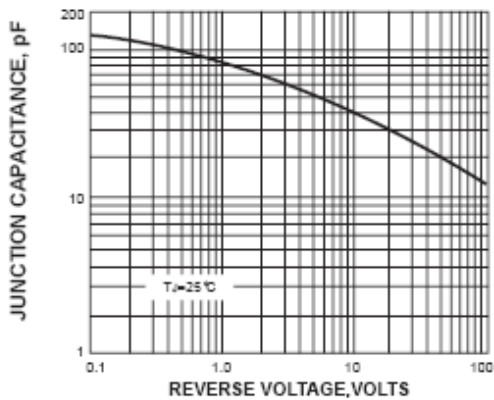
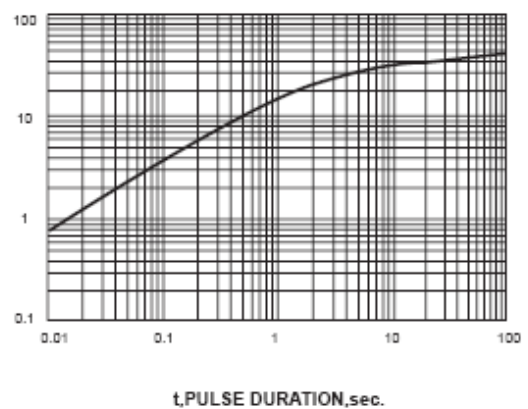

FIG. 5-TYPICAL JUNCTION CAPACITANCE



TRANSIENT THERMAL IMPEDANCE,
°C/W

FIG. 6-TYPICAL TRANSIENT THERMAL IMPEDANCE



DISCLAIMER:

- 1- The information given herein, including the specifications and dimensions, is subject to change without prior notice to improve product characteristics. Before ordering, purchasers are advised to contact the SMC - Sangdest Microelectronics (Nanjing) Co., Ltd sales department for the latest version of the datasheet(s).
- 2- In cases where extremely high reliability is required (such as use in nuclear power control, aerospace and aviation, traffic equipment, medical equipment, and safety equipment), safety should be ensured by using semiconductor devices that feature assured safety or by means of users' fail-safe precautions or other arrangement.
- 3- In no event shall SMC - Sangdest Microelectronics (Nanjing) Co., Ltd be liable for any damages that may result from an accident or any other cause during operation of the user's units according to the datasheet(s). SMC - Sangdest Microelectronics (Nanjing) Co., Ltd assumes no responsibility for any intellectual property claims or any other problems that may result from applications of information, products or circuits described in the datasheets.
- 4- In no event shall SMC - Sangdest Microelectronics (Nanjing) Co., Ltd be liable for any failure in a semiconductor device or any secondary damage resulting from use at a value exceeding the absolute maximum rating.
- 5- No license is granted by the datasheet(s) under any patents or other rights of any third party or SMC - Sangdest Microelectronics (Nanjing) Co., Ltd.
- 6- The datasheet(s) may not be reproduced or duplicated, in any form, in whole or part, without the expressed written permission of SMC - Sangdest Microelectronics (Nanjing) Co., Ltd.
- 7- The products (technologies) described in the datasheet(s) are not to be provided to any party whose purpose in their application will hinder maintenance of international peace and safety nor are they to be applied to that purpose by their direct purchasers or any third party. When exporting these products (technologies), the necessary procedures are to be taken in accordance with related laws and regulations..